

# Compact Refrigerator

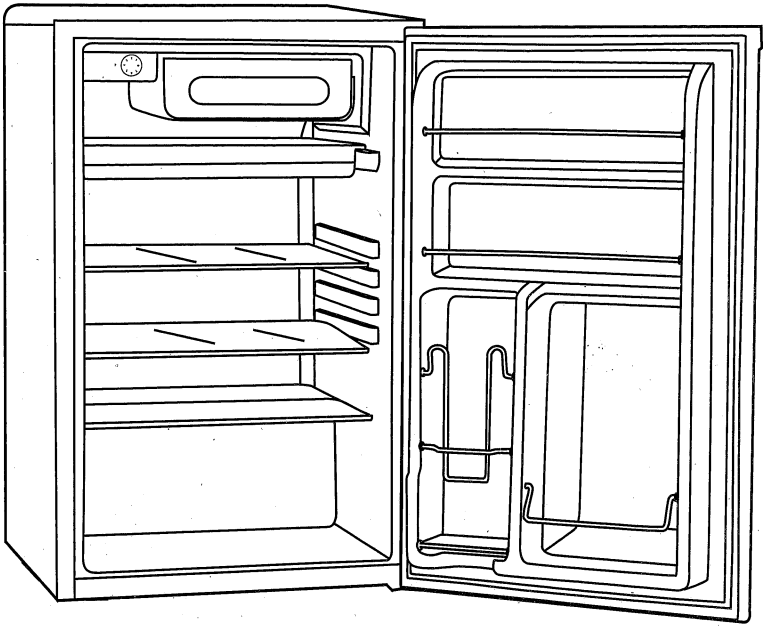

User Manual

BC-128

# IMPORTANT SAFETY INSTRUCTIONS

- 1) Use this appliance only for its intended purpose as described in this use and care guide.
- 2) This refrigerator must be properly installed in accordance with the installation instructions before it is used. See grounding instructions in the installation section.
- 3) This refrigerator should not be recessed or built-in an enclosed cabinet. It is designed for freestanding installation only.
- 4) Never unplug your refrigerator by pulling on the power cord. Always grasp the plug firmly and pull straight out from the outlet.
- 5) Repair or replace immediately, all electric service cords that have become frayed or otherwise damaged. Do not use a cord that shows cracks or abrasion damage along its length, the plug or the connector end.
- 6) If your old refrigerator is not being used, we recommend that you remove the doors. This will reduce the possibility of danger to children.
- 7) After your refrigerator is in operation, do not touch the cold surfaces in the freezer compartment, particularly when hands are damp or wet. Skin may adhere to these extremely cold surfaces.
- 8) Do not refreeze foods, which have been thawed completely. The United States Department of Agriculture in Home and Garden Bulletin No. 69 reads: "...You may safely refreeze frozen foods that have thawed if they still contain ice crystals or if they are still cold-below 40°F.

"...Thawed ground meats, poultry, or fish that have any off-odor or offcolor should not be refrozen and should not be eaten. Thawed ice cream should be discarded. If the odor or color of any food is poor or questionable, discard it. The food may be dangerous to eat.

"...Even partial thawing and re-freezing reduce the eating quality of foods, particularly fruits, vegetables, and prepared foods. The eating quality of red meats is affected less than that of many other foods. Use refrozen foods as soon as possible, to save as much of they're eating quality as you can."

- 9) Do not use any electrical device or any sharp instrument in defrosting your refrigerator.
- 10) Unplug your refrigerator before cleaning or before making any repairs.  
**Note:** If for any reason this product requires service, we strongly recommend that a certified technician perform service.
- 11) Do not operate your refrigerator in the presence of explosive fumes.

## **SAVE THESE INSTRUCTIONS**

**For Future Use**

# **DANGER**

**Risk of child entrapment. Before you throw away your old refrigerator or freezer, take off the doors. Leave the shelves in place so that children may not easily climb inside.**

# TABLE OF CONTENTS

**PAGE**

|   |          |
|---|----------|
| <b>Safety Precautions .....</b>                       | <b>1</b> |
| <b>Parts And Features .....</b>                       | <b>4</b> |
| <b>Energy Saving Tips .....</b>                       | <b>5</b> |
| Refrigerator Installation .....                       | 5        |
| Electrical Connections.....                           | 5        |
| Use of Extension Cords.....                           | 5        |
| <b>Reversing the Door Hinge .....</b>                 | <b>6</b> |
| <b>Operating your Refrigerator.....</b>               | <b>7</b> |
| Temperature Control Dial .....                        | 7        |
| Freezer Compartment & Use of the Ice Cube Trays ..... | 7        |
| Dispense-A-Can™ .....                                 | 7        |
| Shelving.....   | 7        |
| <b>Care and Cleaning .....</b>                        | <b>7</b> |
| <b>Vacation and Moving.....</b>                       | <b>8</b> |
| <b>Defrosting .....</b>                               | <b>8</b> |
| <b>Troubleshooting .....</b>                          | <b>9</b> |

## PARTS AND FEATURES

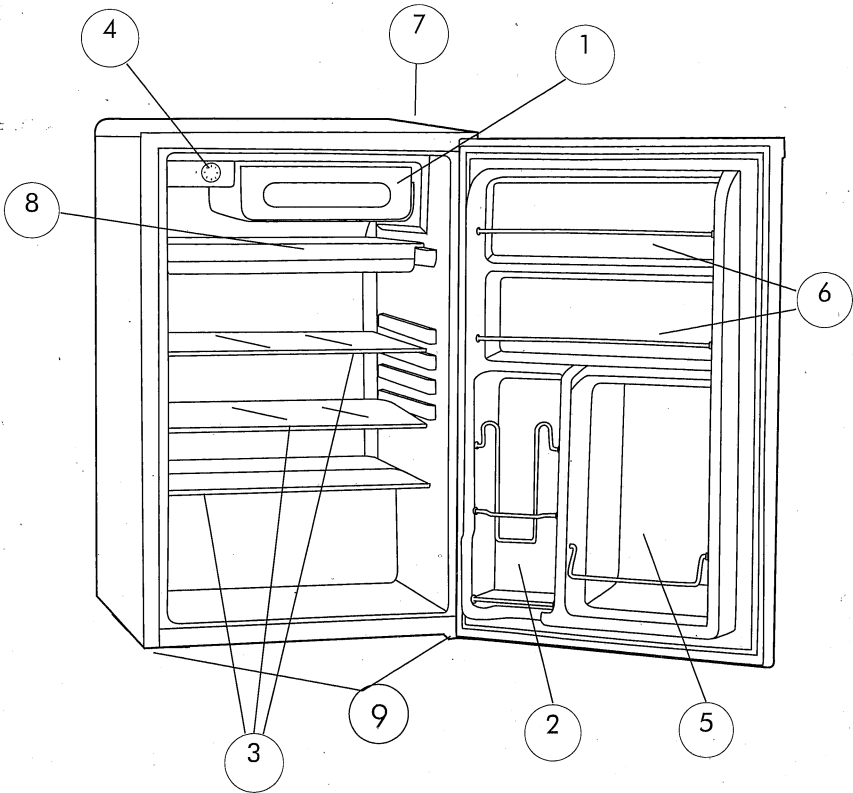

- |                                   |                                  |
|-----------------------------------|----------------------------------|
| 1. Half-width Freezer             | 6. Full-width Door Storage Racks |
| 2. Dispense-A-Can™ Storage        | 7. Work Top                      |
| 3. Removable Shelves              | 8. Storage / Drip Tray           |
| 4. Adjustable Temperature Control | 9. Adjustable Leveling Legs      |
| 5. Tall Bottle Storage            |                                  |

## ENERGY SAVING TIPS

- Do not place your refrigerator next to a heating vent, a range, or in direct sunlight.
- Do not open door more often than necessary.
- Keep the door closed as much as possible, especially, in hot and humid weather.
- Cover foods to reduce moisture build up inside the refrigerator.
- Store only foods that require refrigeration.
- For proper air circulation, do not overfill your refrigerator shelves.

## Refrigerator Installation

The refrigerator is designed for freestanding installation only. It should not be built-in. Allow a minimum of 2 inches on each side and above the top of the refrigerator to ease installation and proper air circulation. Be sure to install your refrigerator on a floor that is strong enough to support the unit when fully loaded.

If the refrigerator is not leveled, adjust the front leveling legs by turning counterclockwise to raise the refrigerator and clockwise to lower it. Do not install your refrigerator where the temperature will fall below 55°F, as it will not run frequently enough to maintain proper temperature.

## Electrical Connections

**Important-for personal safety, this appliance must be properly grounded.**

In the event of an electrical short circuit, grounding reduces the risk of electric shock by providing an escape wire for the electric current. This appliance is equipped with a cord having a grounding wire with a grounding plug. The plug must be plugged into an outlet that is properly installed and grounded. Consult a qualified electrician or service center if the grounding instructions are not completely understood. If doubt exists as to whether the appliance is properly grounded, have a qualified electrician check the circuit to make sure the outlet is properly grounded.

**Do not, under any circumstances, cut or remove the third (ground) prong from the power cord.**

## Use of Extension Cords

Avoid the use of an extension cords due to potential safety hazards under certain conditions. If it is necessary to use an extension cord, use only a 3-wire extension cord that has a 3-blade grounding plug and a 3-slot outlet that will accept the plug. The marked rating of the extension cord must be equal to or greater than the electrical rating of the appliance.

## REVERSING THE DOOR HINGE

1. Remove the top hinge cover.
2. Using Phillips Head Screwdriver, loosen and remove the screws holding the top hinge in place.
3. Remove top hinge and carefully lift off the door.
4. Remove the screw hole plugs from the opposite side and insert the plugs in the screw hole openings of the just removed screws.
5. Remove any loose items in the refrigerator and carefully turn refrigerator on its back, remove both leveling legs and place in a secure area.
6. Loosen the screws holding the lower hinge bracket to the refrigerator and remove screws and bracket.
7. Remove (2) screws from the other side and insert in the previously removed screw holes.
8. Remove door pin by turning counter clockwise and reinsert to the underside of the bracket and tighten.
9. Align bracket and insert (2) remaining screws into the holes provided.
10. Align hole in the door with the door pin and washer and gently push down until firm.
11. Align upper hinge bracket with screw holes insert screws and partially secure, check that door and cabinet are properly aligned and then secure tightly.
12. Replace hinge cap.

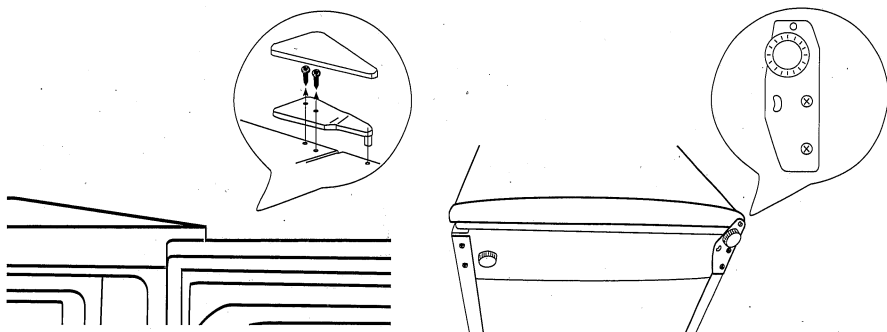

## OPERATING YOUR REFRIGERATOR

### TEMPERATURE CONTROL DIAL

The temperature control dial has settings from

- "0" - "7"
- "0" is Off
- "1" is the warmest
- "7" is the coldest

Initially, set the temperature control dial to "4".

After using the refrigerator for 24 hours, adjust the temperature control dial to the setting that best suits your needs. Turning the temperature control dial '0' stops the cooling cycle; however, it will not shut off power to the refrigerator.

**(Important:)** If you unplug or turn off the refrigerator, allow 4 minutes before restarting it or re-plugging it in.

### FREEZER COMPARTMENT & USE OF THE ICE CUBE TRAYS

This compartment is designed for making ice cubes and for short-term food storage (a few days at most). This compartment is not cold enough to freeze foods safely for extended periods of time.

- If ice cube tray freezes to the floor, pour a little warm water around it to loosen it. Do not use boiling water, which can damage plastic parts, or sharp metal objects such as a knife or screwdriver, which can damage the cooling system tubing.

Wash tray in lukewarm water only. Do not wash in the dishwasher.

### DISPENSE-A-CAN

The refrigerator has a convenient Dispense-A-Can™ storage compartment. Simply stack cans vertically, loading from the top and drawing them from the bottom.

### SHELVING

The refrigerator has shelves that can be adjusted to different levels that will suit your food storage needs. The door shelves provide storage for small and large items.

## CARE AND CLEANING

### CLEANING THE OUTSIDE

Clean the outside of the refrigerator with a damp cloth and dry thoroughly. To clean the door gasket, use only mild soapy water. Never use harsh cleansers or a scouring pad to clean any part of the refrigerator. For efficient operation dirt and dust should be removed from the back every three months. Turn the temperature control to the "OFF" position and unplug the refrigerator. Carefully slide the refrigerator away from the wall so as not to damage the floor below. Wipe dust from the back of refrigerator with a clean dry cloth use a vacuum cleaner with a brush attachment to clean the compressor area.



## CLEANING THE INSIDE

Clean the inside of the refrigerator at least twice a year. Turn the temperature control dial to "OFF" unplug the refrigerator and remove food and shelves. Wash inside with warm water and baking soda solution. (2 tablespoons of baking soda to one quart of water), then rinse and dry thoroughly. Do not use cleaners such as harsh detergents, scouring powder or sprays containing bleach, ammonia, or other chemicals that may cause odors inside the refrigerator or damage to the refrigerator.

Wash the ice cube tray, drawers and shelves in mild detergent solution, rinse thoroughly and dry with a soft cloth. To help prevent odors, leave an open box of baking soda in the refrigerator. Change the box every three months.

## VACATION AND MOVING

### WHEN NOT IN USE:

If your refrigerator will not be used for a period of time turn the unit off and unplug it. Clean the refrigerator (see Care and Cleaning instructions).

### MOVING THE REFRIGERATOR:

When transporting the refrigerator it must be kept in the upright position. If the refrigerator is inadvertently tilted beyond 45 degrees, place it in the upright position and wait 24 hours before plugging in.

## DEFROSTING

Defrost whenever frost on the wall of the freezer compartment becomes 1/8" thick. Never use a sharp or metallic instrument to remove frost as it may damage the cooling coils. (A punctured cooling coil will cause serious damage to the product and will void the warranty). We recommend using a plastic scraper. To defrost, remove foods and ice cube tray from the freezer compartment. Put the drip tray in place and set the temperature control dial to the "OFF" position. Defrosting usually takes a few hours. To defrost faster, keep the door open and place a bowl of warm water in the refrigerator. After defrosting, empty water from the drip tray and wash the drip tray in warm water.

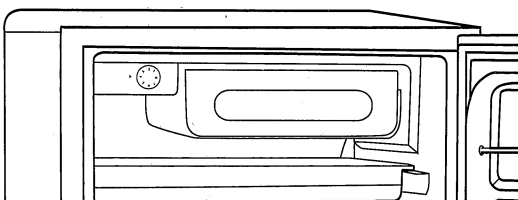

## **TROUBLESHOOTING**

### **Refrigerator does not operate.**

- The unit may not be plugged in.
- Circuit breaker may have tripped or fuse may be blown.

### **Refrigerator seems to run longer or more often than necessary.**

- The door may have been left open
- Frequent door openings lets the cold air escape.
- Air is not circulating freely, remove the refrigerator from the wall and clean.

### **Refrigerator vibrates.**

- Check to be sure that the refrigerator is leveled, if not adjust the leveling legs.

### **Refrigerator compartment has an odor.**

- Foods with strong odors should be tightly covered.
- Check for spoiled food.
- Interior may need cleaning
- Keep an open box of baking soda in the refrigerator. (Replace every three months).

### **Foods are not cold enough.**

- The temperature setting is not high enough.
- The door has been left open.
- Frequent door openings will let the cold air escape.
- Circulation of air inside the refrigerator is blocked because the shelves are too full.

### **The walls on the inside of the refrigerator are damp.**

- The door has been left open.
- Frequent door openings let moisture in.
- The room is warm and there is high humidity.
- Warm foods have been placed in the refrigerator.
- Foods are stored in the refrigerator uncovered.

## **POWER INTERRUPTIONS**

- Occasionally there may be power interruptions due to thunderstorms or other causes. Remove the power cord from AC outlet when a power outage occurs. When power has been restored, replug power cord to AC outlet. If outage is for a prolonged period, inspect and discard spoiled or thawed food in freezer. Clean freezer before reusing.